

PV-ezRack SolarTerrace V

Installation Guide V1.3

NO.: PZ24-IM01-13

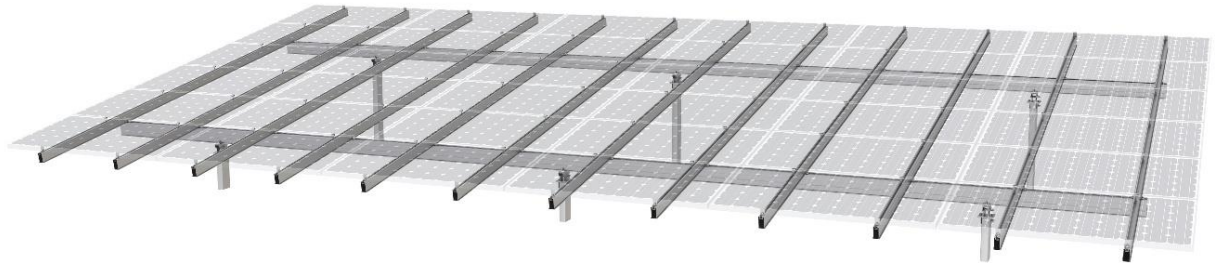

Content

1. Introduction.....	1
2. Tools & Components.....	2
3. System Overview.....	5
4. Installation Instructions.....	6

1. Introduction









PV-ezRack SolarTerrace V is developed for utility scale PV installation with panels in landscape orientation. The system offers a wide range of adjustability, easy deployment and enables the implementation of large arrays. STV is a simple and robust structure so it can be installed even with untrained labour forces. All these features result in fast, easy and cost efficient installation. Main aluminium components have a standard 10µm anodisation thickness which ensures a long life circle.

Please review this manual thoroughly before installing PV-ezRack Solar Terrace V. The manual provides the following content: (1) simple introduction of installation; (2) product installation specification;



When installed in accordance with this guide, the PV-ezRack Solar Terrace V parts will be structurally adequate and will adhere to the JIS C 8955:2011 standard. During installation and especially when working on the ground please comply with the appropriate occupational health and safety regulations. Please also pay attention to other relevant regulations of your local region. Please check that you are using the latest version of the installation manual by contacting Clenergy International via email at sales@clenergy.com.cn, or by contacting your local distributor.

2. Tools & Components

2.1 Tools

Tools			
			
Tape Measure (5m)	Marker & String	Total station or the equivalent	Allen Key 6 mm
			
Spanner	Power Tool	Socket Wrench	Torque Wrench

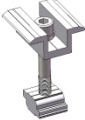
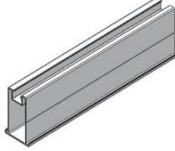
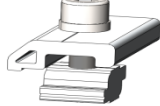
2.2 Components List

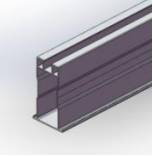
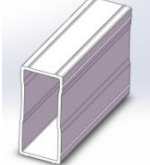
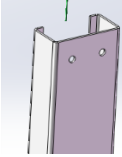
Components			
			
ER-EC-ST End clamp	ER-IC-ST/U18 Inter clamp	ER-R-T110 T rail 110	ER-RC-T Rail Clamp for T Rail
			
ER-PH-CP/140 Post Head for C post 140	ER-R-T160 Clipped T-Rail 160	ER-SP-T160 Splice for Clipped T-160 Rail	ER-CP-140 C post 140

2.3 Stainless Steel Fastener Installation Precautions

Improper operation may lead to deadlock of Bolts and Nuts. Follow the steps below to reduce this risk

1. Reduce the friction coefficient:

- (1) Ensure that the thread surface is clean (no dirt or contaminant)
- (2) Apply lubricant (grease or 40# engine oil) to fasteners prior tightening to avoid galling or seizing in the threads;

2. General installation instructions:

- (1) Apply force to fasteners in the direction of thread;
- (2) Apply force uniformly, to maintain required torque;
- (3) Professional tools and tool belts are recommended;
- (4) Avoid using electric tools for final tightening;
- (5) Avoid working at high temperatures,

3. Safe Torques

Please refer to safe torques defined in this guide as shown in below figure. In case power tools are required, Clenergy recommends the use of low speed only. High speed and impact drivers increase the risk of bolt galling (deadlock) If deadlock occurs and you need to cut fasteners please make sure that there is no load on the fastener before you cut it. Avoid damaging the anodized or galvanized surfaces.

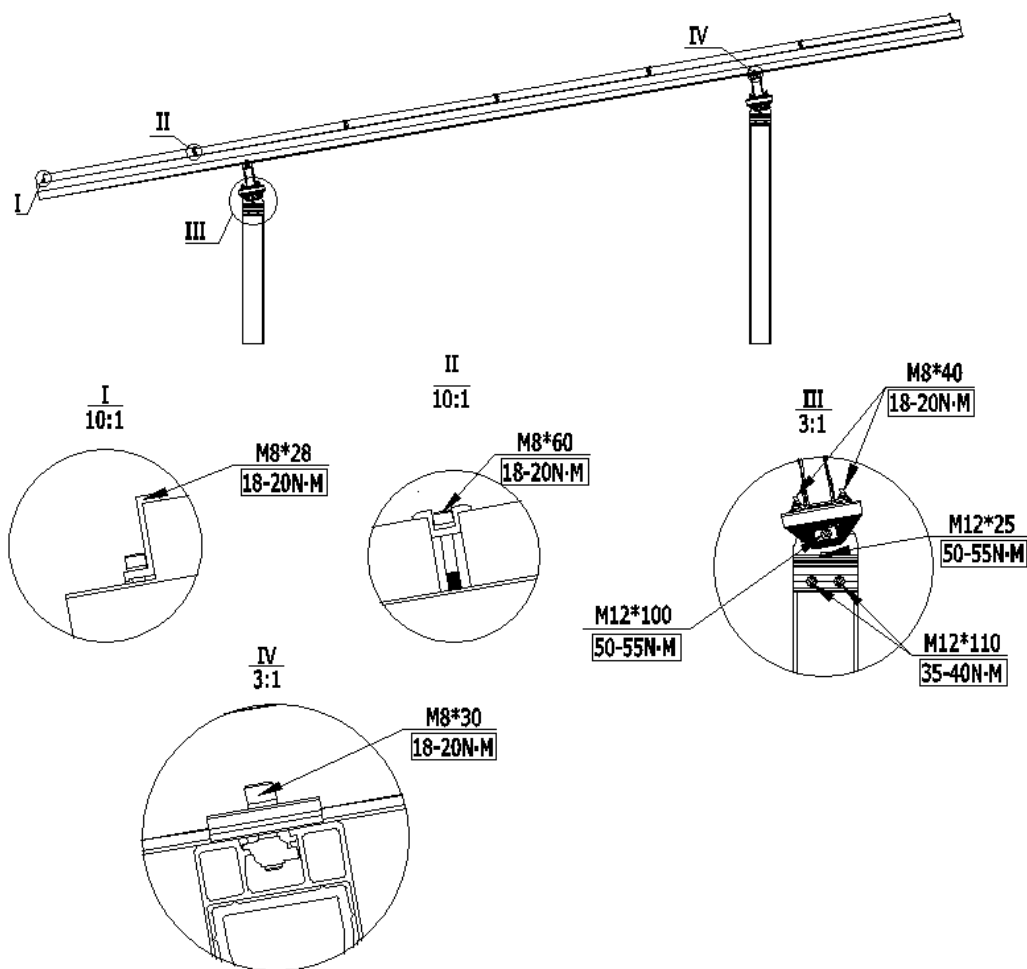

Notes: Tighten the bolts after all the components in place. Repeat the lock and loosen, it will make bolt deadlock.

4. Installation Instructions

4.1 Install the Post

4.1.1 Before installation, please prepare the products and installation tools. Make sure the Hydraulic pile driver equipment can be applied in the construction work.



4.1.2 Mark the position of the Posts array. Define the distance of two posts, if you have no calculated tool please contact Clenergy customer services. Drive the piles into the earth with the help of a string to make sure all the posts are in the same line and height.

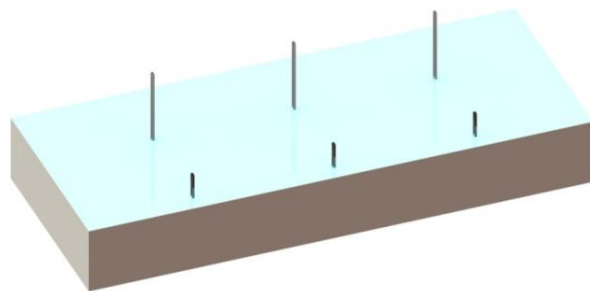

Note: Please make sure C-posts open their mouth to the same orientation.

4.2 Install Post Head

4.2.1 Install the Post Head and fix it with M12*110 Hexagonal Bolt and Nut, as shown in figure.

Note:

Add grease lubrication when you locking. Control the speed of Power tool.

Recommended torque : M12

35~40N·m

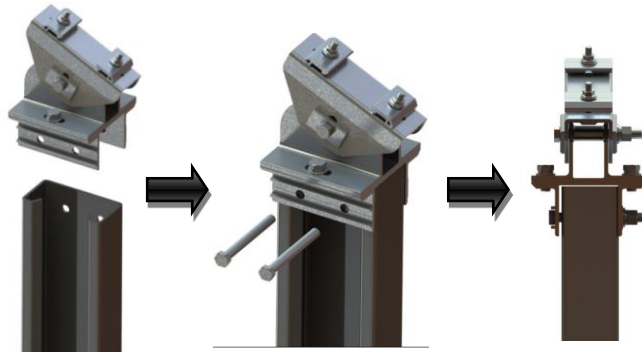

4.3 Install the Clipped T-160 Rail

5.3.1 Make sure the length of Clipped T-160 Rail is long enough before connecting.

Splice for Clipped T-160 Rail can be used to extend the rails.

Note:

It is not recommended to place the splice on the position of Post Head.

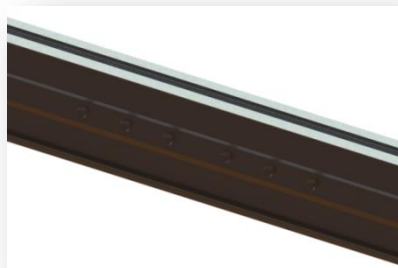

4.3.2 Attach Clipped T-160 Rail to Post Head for C post 140 with one T Rail Clamps on each side.

(Recommended torque: M8 18~20N·M)

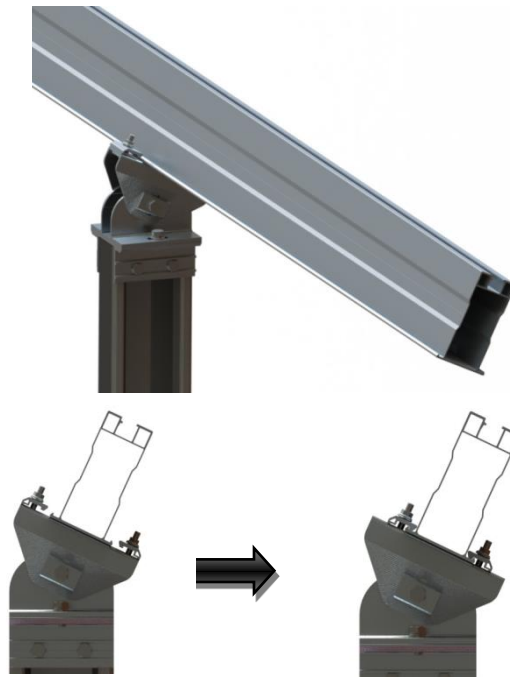

4.3.3 As figure, Clipped T-160 Rail will be installed in the pre-assembly joints.

Adjust and make sure the two Clipped T-160 Rails will be aligned at end faces and then fasten bolts by power tool.

Note:

Add grease lubrication when you locking.

Control the speed of power tool.

(Recommended torque :

M8 18~20N·M)

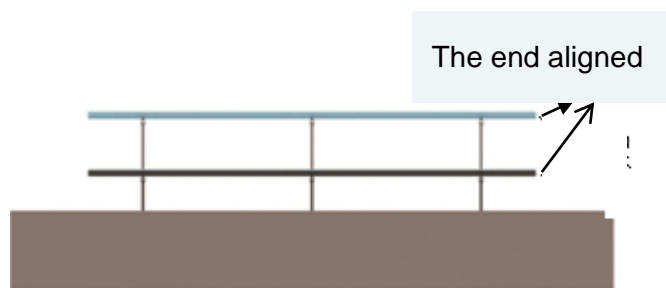
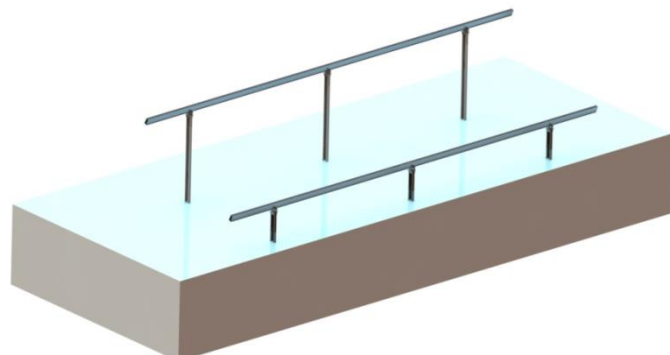

4.4 Install the T Rail 110

4.4.1 Placed the T rail 110 at the planned location.

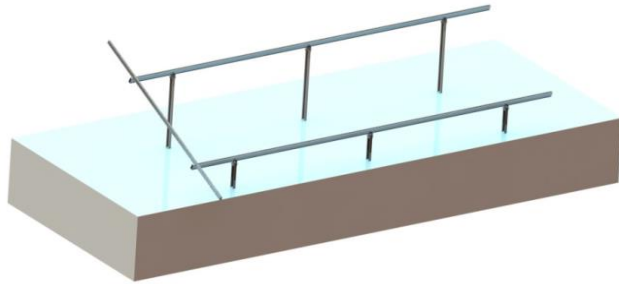

4.4.2 Attach T Rail 110 to Clipped T Rail 160 with one T Rail Clamps on each side. Use 6mm Allen to lock.

Recommended torque:
M8 18~20N·M

Note:

a、Adjustment pre-assembly joint angle, ensure the bottom face of T Rail 110 affix the top face of Clipped T Rail 160. As shown in right figure.

b、Make sure the length of T Rail 110 is long enough before connecting.

Note:

It is not recommended to splice T Rail 110 on Clipped T Rail 160.

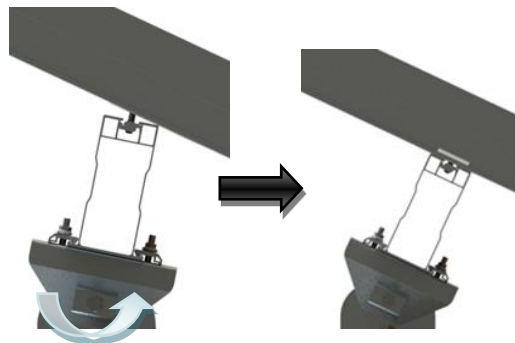
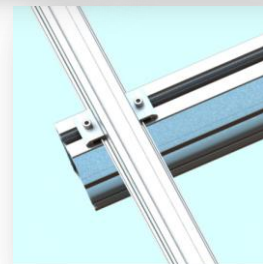
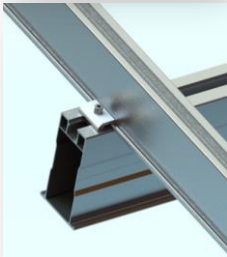
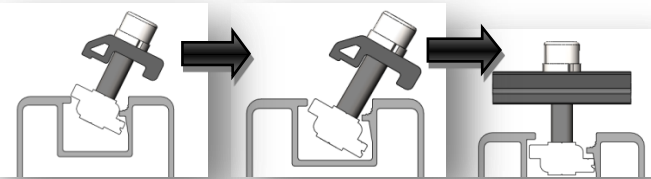

4.4.3 Repeat the above steps, to install the rest Rails. Locking joint with M12 socket wrench. Keep each rail of its ends aligned.

Recommended torque:
 M12 50~55N·M

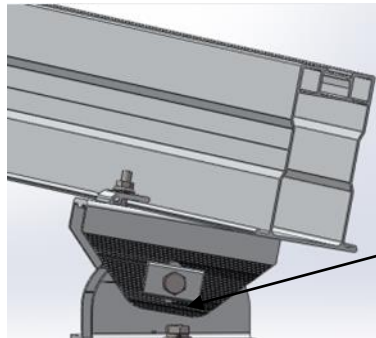
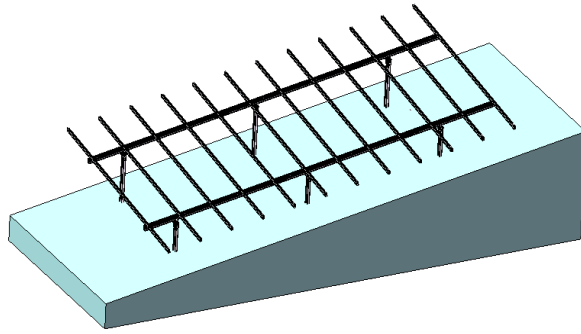

Locking rotating joint with M12 socket wrench

4.5 Install PV-Modules

4.5.1 Place PV-Modules on the T Rail 110, and fix them with the End Clamp and the Inter Clamp. Then use the 6mm Allen to tighten the Clamps.

Recommended torque:
 M8 18~20N·M

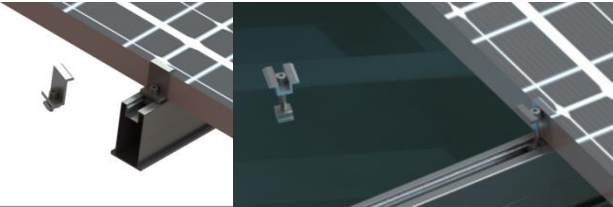

4.5.2 Repeat above steps to install the rest PV-Modules with the clearance between any adjacent side face of them to be 20mm.

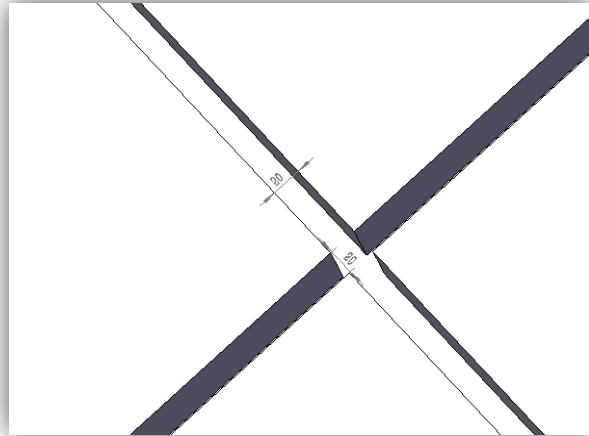

4.5.3 Complete installation as shown in the right figure.

