

Important Safety Information



Warning - Risk of Electric Shock

Failure to comply with these warnings and instructions can result in damage to property, risk of fire, serious injury or death.

- Do not remove the covers. The unit contains no user serviceable parts. Hazardous voltage is present inside the unit from both DC and AC sources. Hazardous voltage remains inside the unit even when disconnected.
- The photovoltaic (PV) array supplies hazardous voltage when exposed to light, even at very low intensity. Even ungrounded photovoltaic arrays present an electric shock hazard through ground capacitance.
- The unit is designed to supply power to the electric grid (AC utility) only. It must not be connected to other AC electric generators or power supplies. This may cause permanent damage to the unit and/or AC power supply.
- The earth connection of the electric grid (AC utility) to the inverter should be firm and visible.
- Connection to the electric grid (AC utility) typically requires a permit or interconnection agreement with the electricity provider. Contact your electricity provider for more information.
- All local and national codes and regulations for installation, wiring and inspection of electrical equipment must be complied with.
- Installation and troubleshooting of this unit must only be performed by properly trained electricians or installation technicians, qualified to install or service PV inverters.
- Incorrect installation, troubleshooting by unqualified persons or modification of the electrical wiring poses a safety risk to the installers, home/facility occupiers and other users/operators of the electric grid (AC utility).

- Both AC and DC voltage sources are terminated inside this equipment. The unit must not be opened until both AC and DC circuits have been individually disconnected for at least 3 hours. (Due to risk of electric shock from energy stored in capacitors.)
- Please take out the unit from the packaging box carefully. Check if there is any obvious damage. Do not install the unit, if it is damaged. Please contact your local dealer for a replacement.
- The SPH inverter is the latest transformer less design. Please check the requirements for your country regarding earthing regulations.

Before you start...

Thank you for purchasing the SPH Grid PV-Inverter. This is a highly reliable product due to innovative design and precise quality control. When installed and operated correctly, it will give many years of trouble free operation.

This manual contains important information for the safe and effective installation and operation of the SPH Grid PV-Inverter. Be sure to read this manual carefully before using the product.

If you encounter any problem during the installation or operation of the unit, please check this manual first before contacting your local dealer or representative. Most of the problems you may encounter can be solved by following the instructions inside the manual.

Please keep this manual in a safe place for later use.

1. SPH inverter overview and connections

1.1. SPH15, SPH20 & SPH30

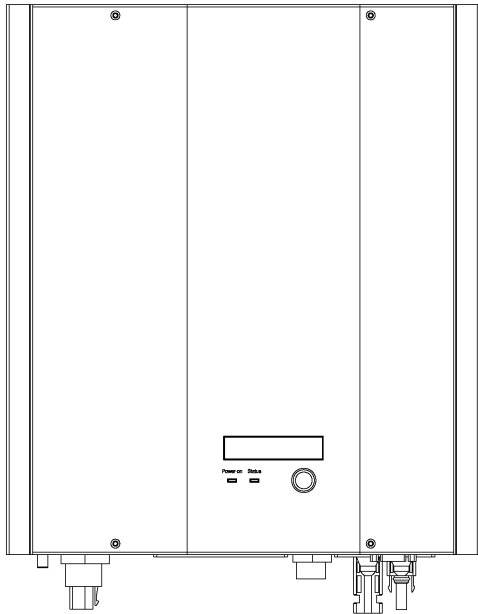

Front view

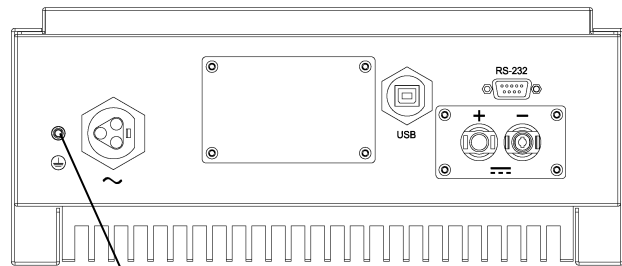

External protective earth (PE)-terminal

Bottom view

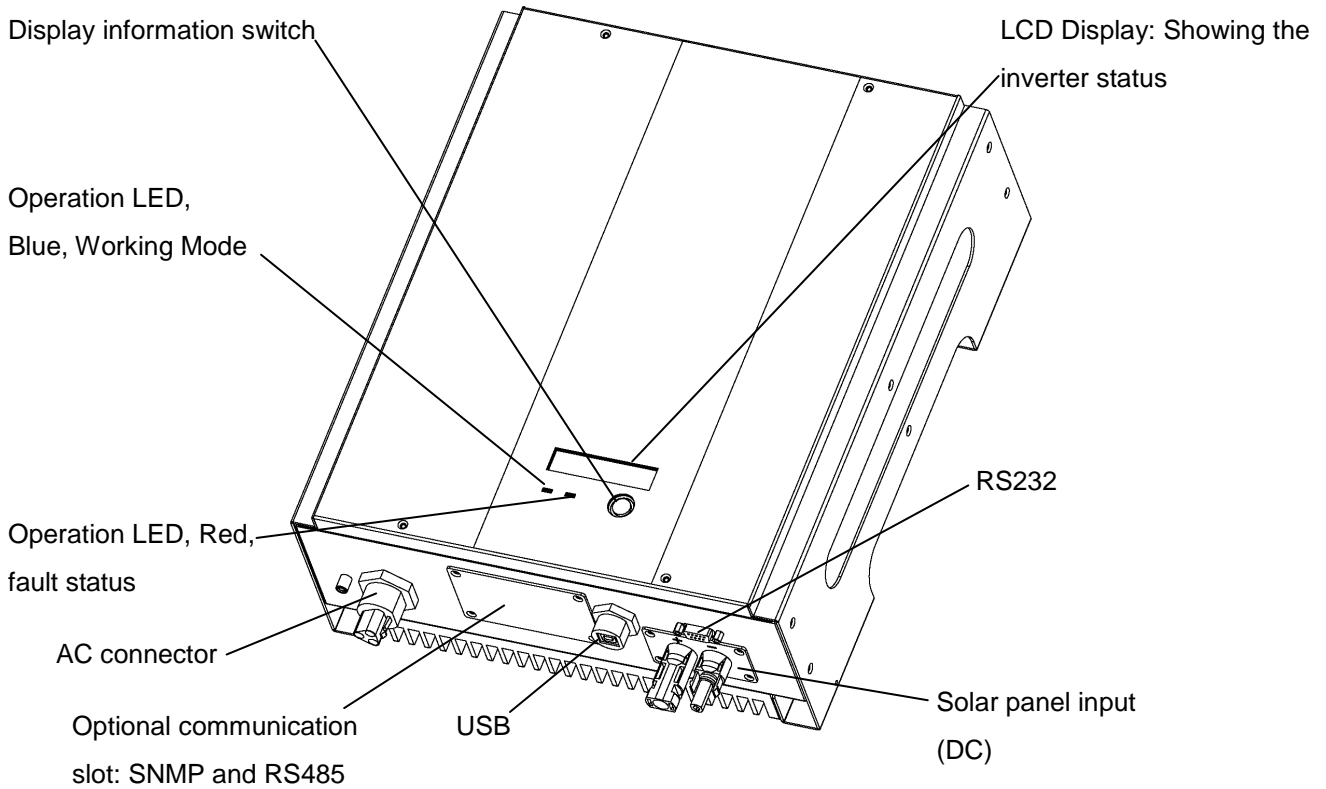

Display and connections

1.2. SPH40

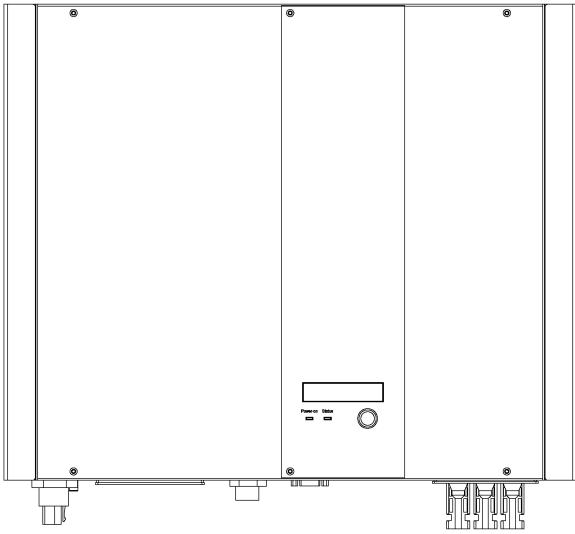

Front view

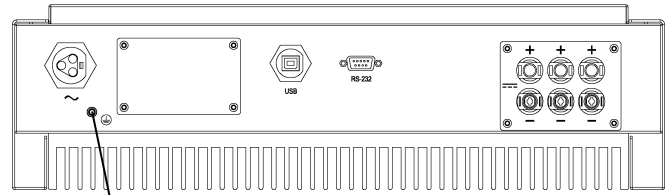

Bottom view

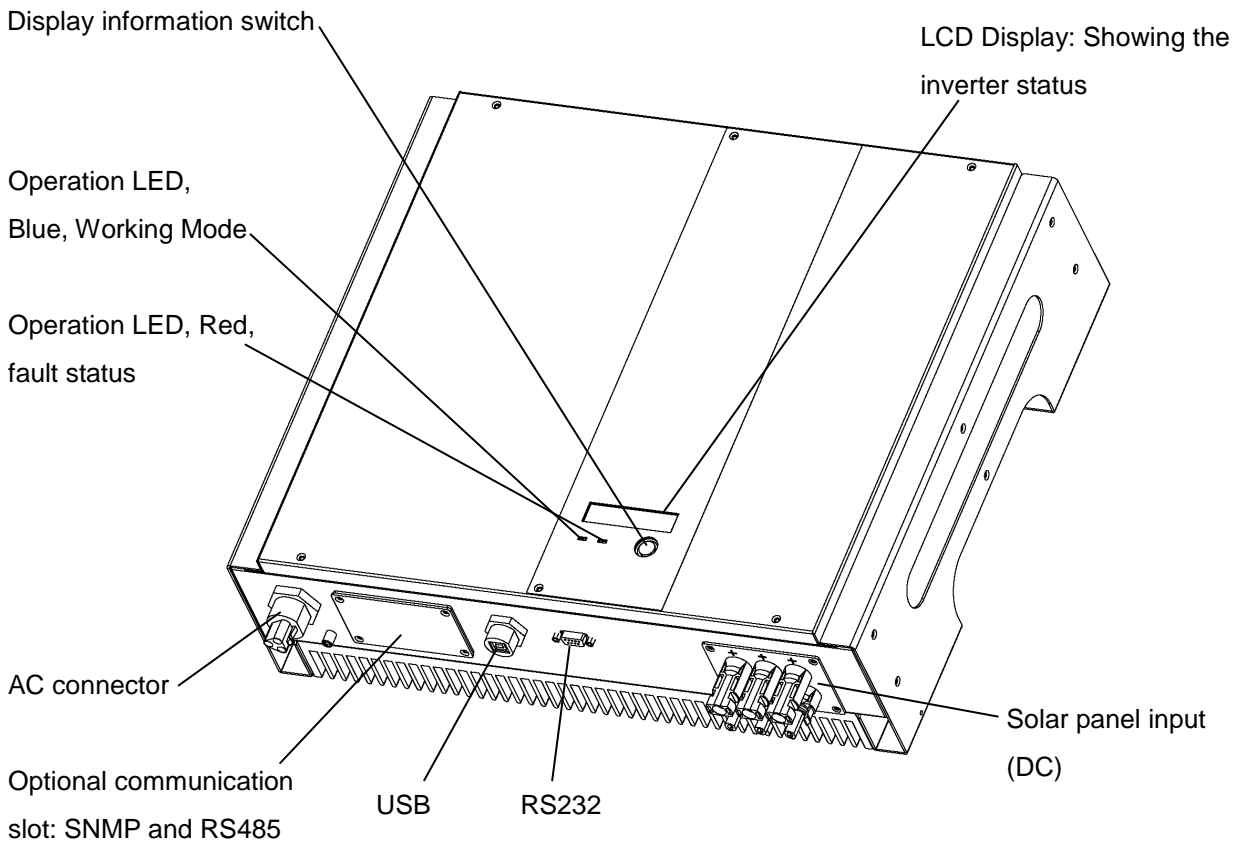

Display and connections

1.3. SPH50 & SPH60

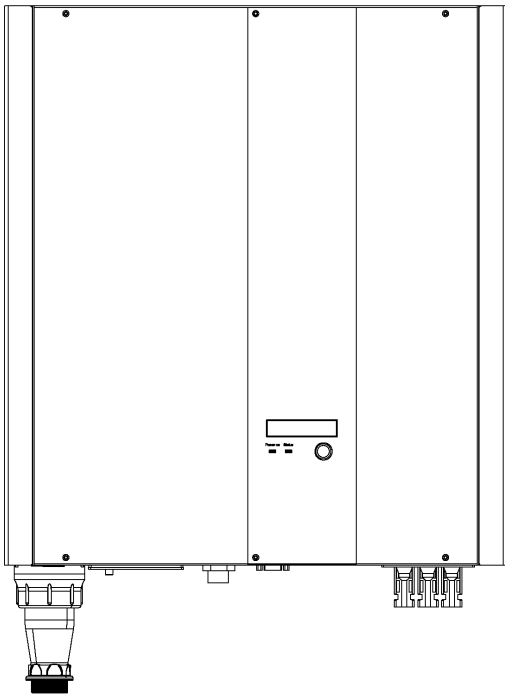

Front view

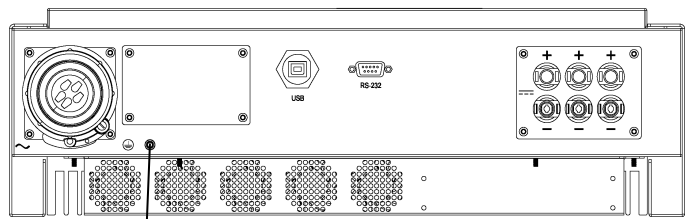

External protective earth (PE)-terminal

Bottom view

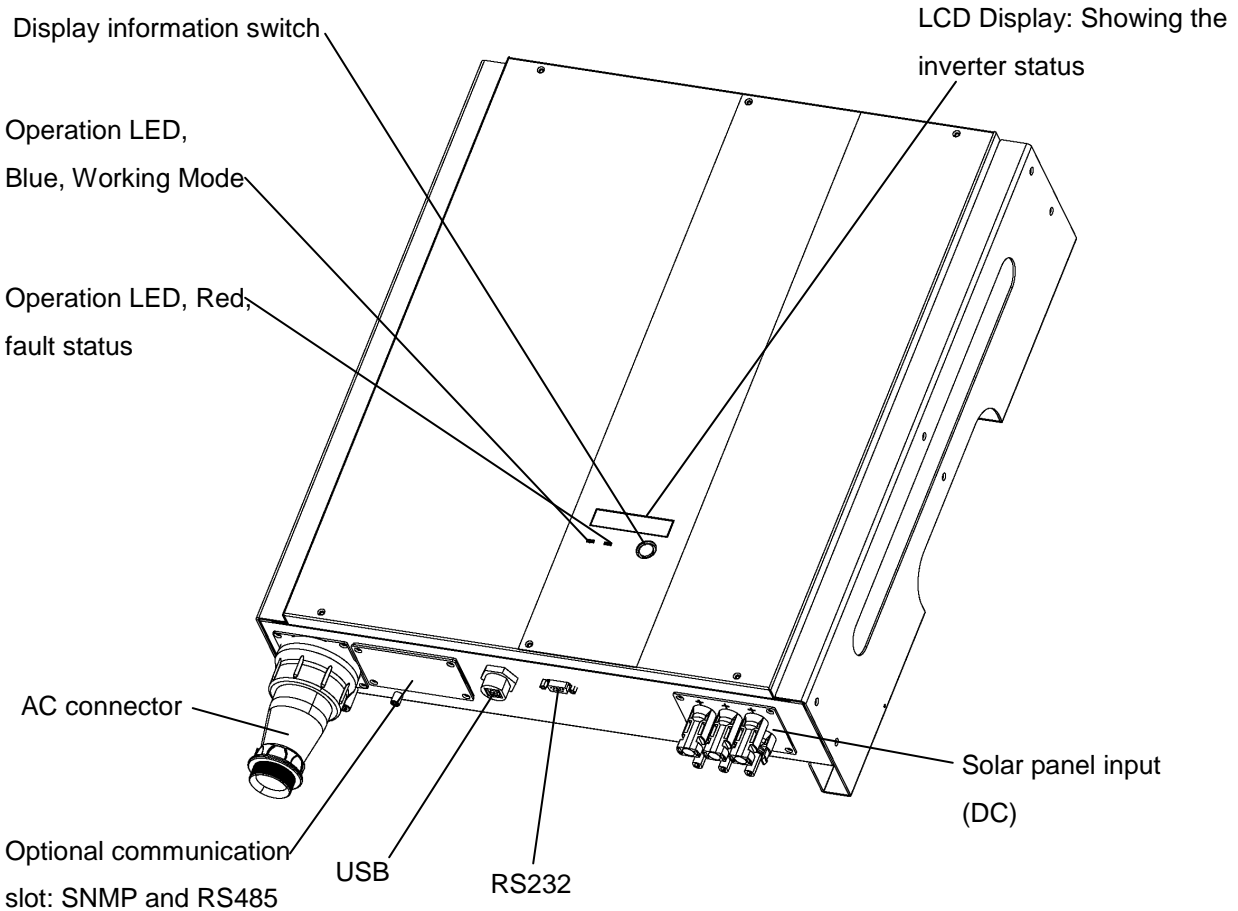

Display and connections

2. PV installation system diagram

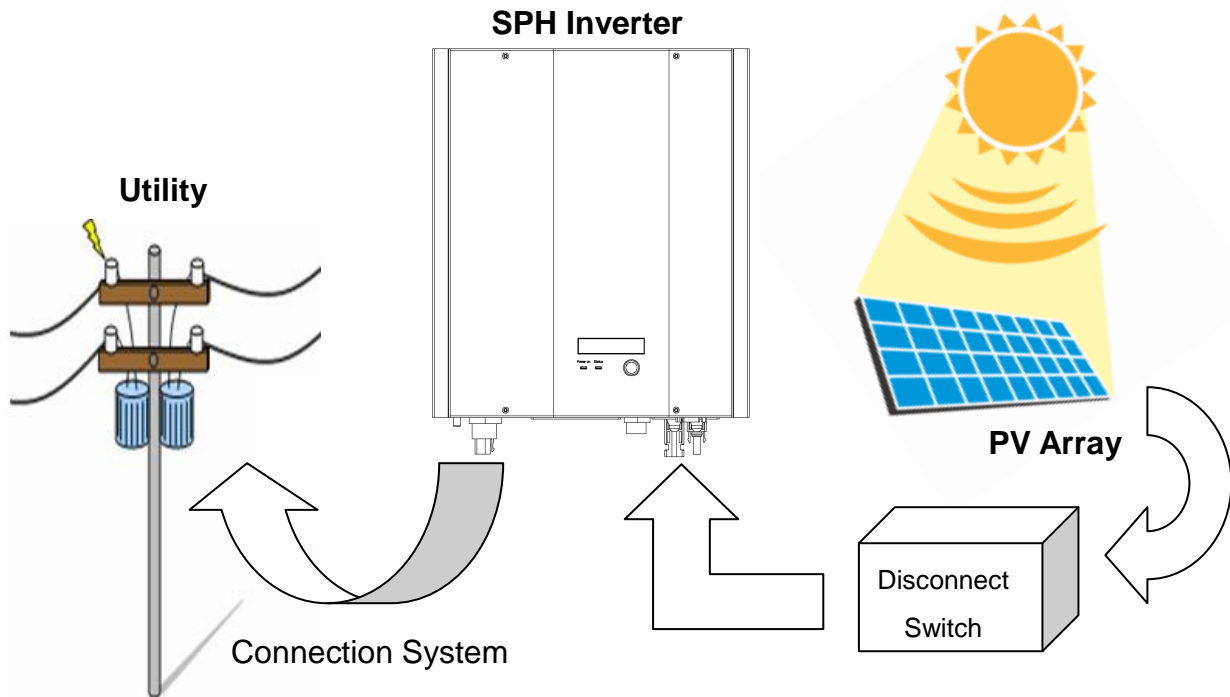

- **PV array:** Provides DC power to the SPH inverter. A DC Disconnect Switch or optional Solar Concentrator is usually fitted between the PV array and the SPH inverter.
- **SPH inverter:** Converts DC power from the PV array into AC power. The AC (Alternating Current) power is supplied to the electric grid (AC utility). The SPH inverter uses Maximum Peak Power Tracking (MPPT) to optimize the PV array operation and deliver maximum power to the electric grid.
- **Connection System:** The “interface” between the SPH inverter and the Grid usually consists of an electrical breaker or fuse and terminals for connection. It may also contain a disconnect switch. For proper safety, this part must be designed by a qualified electrician or electrical installation technician.
- **Utility:** The electricity supply from the main electric grid system must be single phase 220V to 250V, 50Hz or 60Hz.

3. Installation

Before starting installation please check the following items:

- This unit is suitable for indoor and outdoor usage. For best performance and service life, outdoor installations should be sheltered from direct exposure to rain and water.
- The unit can operate with an ambient temperature of -25°C to $+55^{\circ}\text{C}$. For best performance and service life, the unit should be operated with an ambient temperature of 0°C to $+40^{\circ}\text{C}$. Above this temperature, the power output may be reduced. It is recommended to shade the unit from direct exposure to sunlight to prevent increased operating temperature.
- The electric grid must be 220V to 250V, 50Hz or 60Hz single-phase.
- Connection to electric grid must be approved by the electricity provider.
- The installation must be done by a certified electrician.
- The unit must be installed vertically in the orientation shown.

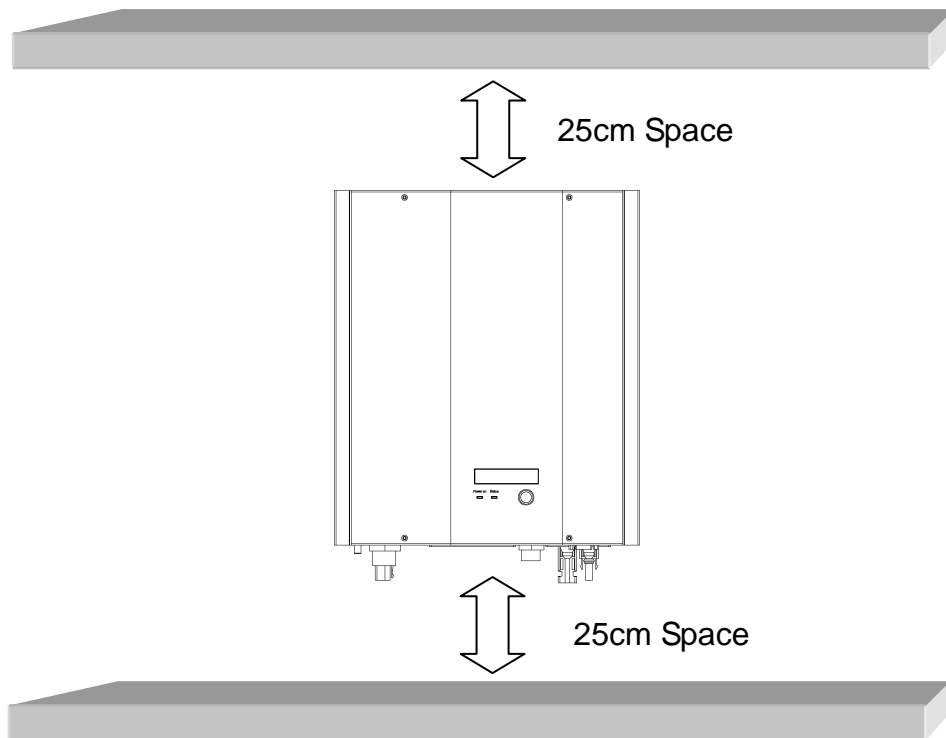

Step1: Mount SPH inverter to the wall or other vertical surface

1. Select a solid wall or vertical surface to mount the unit. The mounting surface must have sufficient strength to carry the weight of the unit (Given in the specification). In areas of seismic activity, additional support or restraint may be necessary. It is recommended that the inverter is installed at a height that provides comfortable viewing and operation of the display and controls.
2. There must be at least 25cm clear space above and below the unit. This is to allow for proper air circulation and convection cooling.
3. Mark the 4 mounting hole positions required using the mounting backplate as a template.

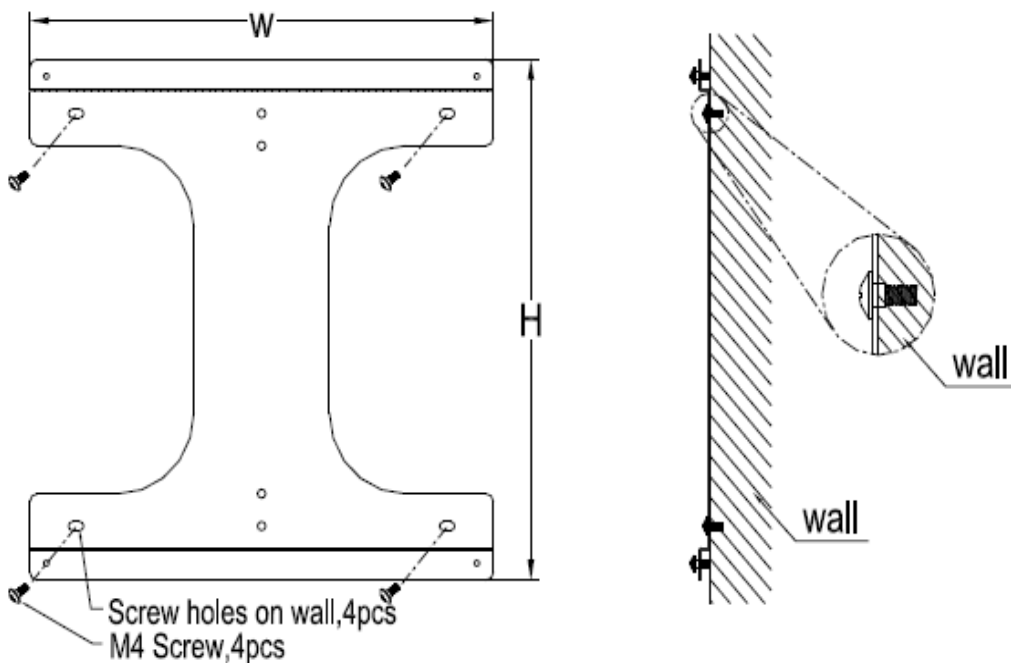

	SPH15	SPH20	SPH30	SPH40	SPH50 SPH60
W (mm)	312	312	312	465	465
H (mm)	362	362	362	386	516
D (mm)	131	131	141	131	142

4. Select appropriate mounting hardware for the type of mounting surface and drill mounting holes of the appropriate size.
5. Fix the mounting backplate to the mounting surface using the selected hardware at each of the 4 mounting holes.
6. Fix four screws with spacer on the four corners of the mounting back plate.
7. Hang the inverter unit onto the mounting back plate and press down.

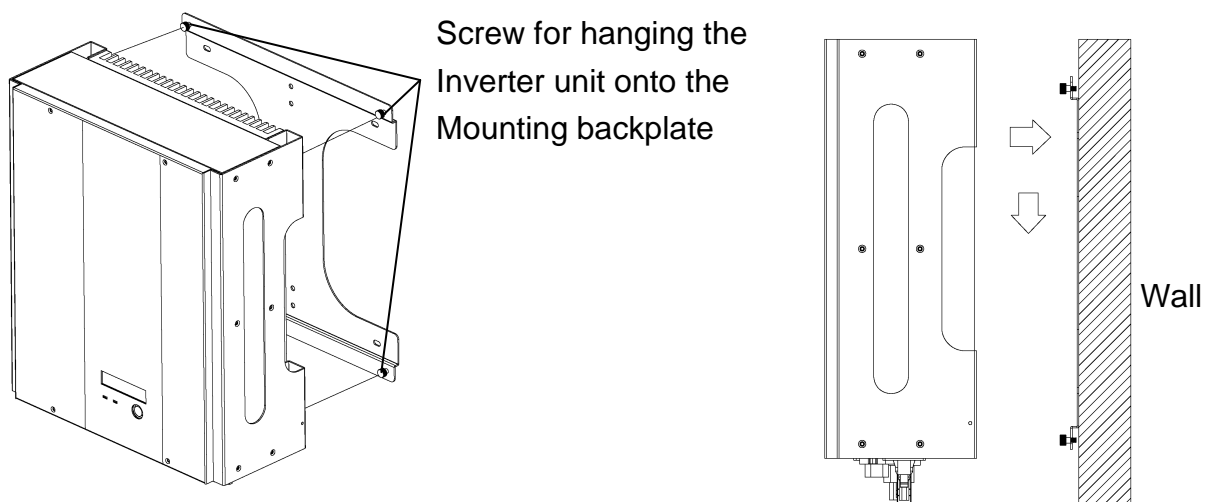

8. Attach the "fix screws" to the bottom sides of the unit to securely attach the inverter to the mounting plate.

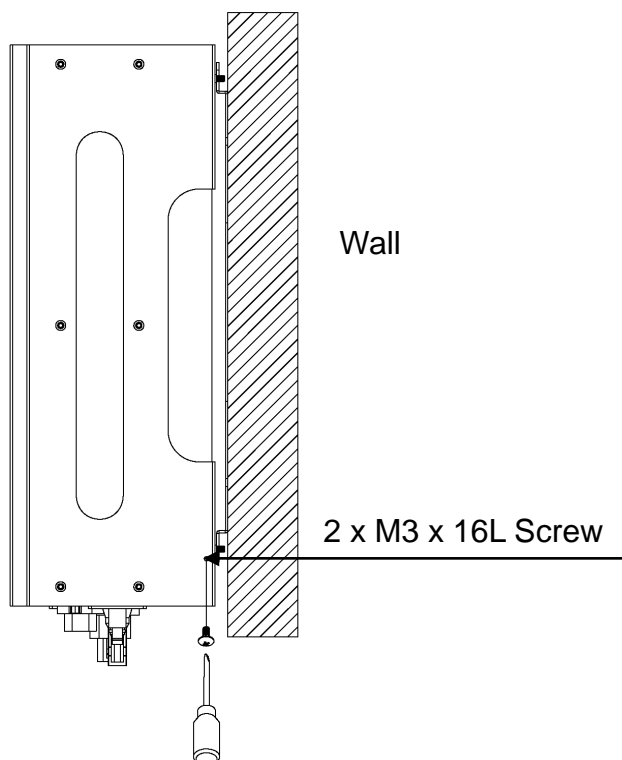

9. Check the unit is securely mounted. Try to lift up the inverter at the bottom to test that it is firmly attached. If not, adjust the mounting as necessary.

CAUTION: The electrical installation of this unit must only be performed by electricians or technicians, qualified to install solar PV inverters.

Step2: Prepare the electric grid (AC utility) connection

1. Verify that the electric grid voltage is 220V to 250V AC single-phase at 50Hz or 60Hz. This information is available from the electricity provider.
2. Ensure that the AC supply wire to the inverter is disconnected from the electric grid. For example, the fuse is removed or the circuit breaker is open. Verify with an AC voltmeter that there is no voltage between the Line and neutral AC wire and between each AC wire and earth ground.
3. The table provided suggests minimum wire sizes for the AC cable. Ensure the selected wire conforms to local and national wiring codes.

Model	ϕ (mm)	AWG no.
1500	≥ 1.29	≤ 16
2000	≥ 1.29	≤ 16
3000	≥ 1.72	≤ 14
4000	≥ 2.05	≤ 12
5000	≥ 2.85	≤ 8
6000	≥ 2.85	≤ 8

4. For SPH15 SPH20 SPH30 SPH40, connect AC wires as follows:
 - Disassemble the AC output female socket.
 - Connect AC wires to connection socket as indicated:

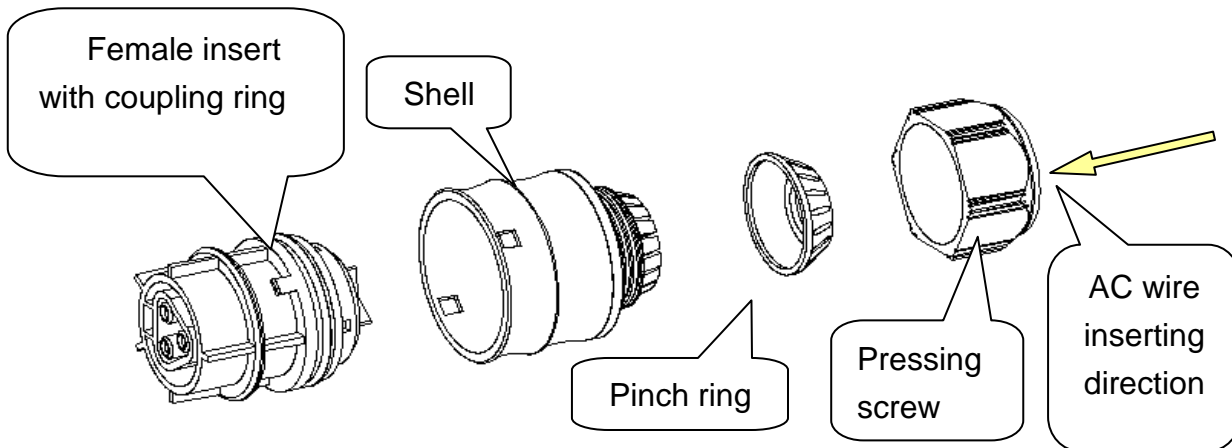

- Strip the wire sheath and conductor insulators the minimum amount necessary to insert the wires into the connection pins.
- Insert Line wire to **L**, Neutral wire to **N** and Ground \oplus wire to pin
- Fully tighten the wire clamp screws in each connection pin.
- Assemble the socket again. Insert the whole socket into the inverter.
- Twist the coupling ring to receptacle on inverter. Make sure it is perfectly matched and tightly fastened.

5. For SPH50 & SPH60, connect AC wires as follows:
- Disassemble the AC output female socket.
 - Connect AC wires to connection socket as indicated:

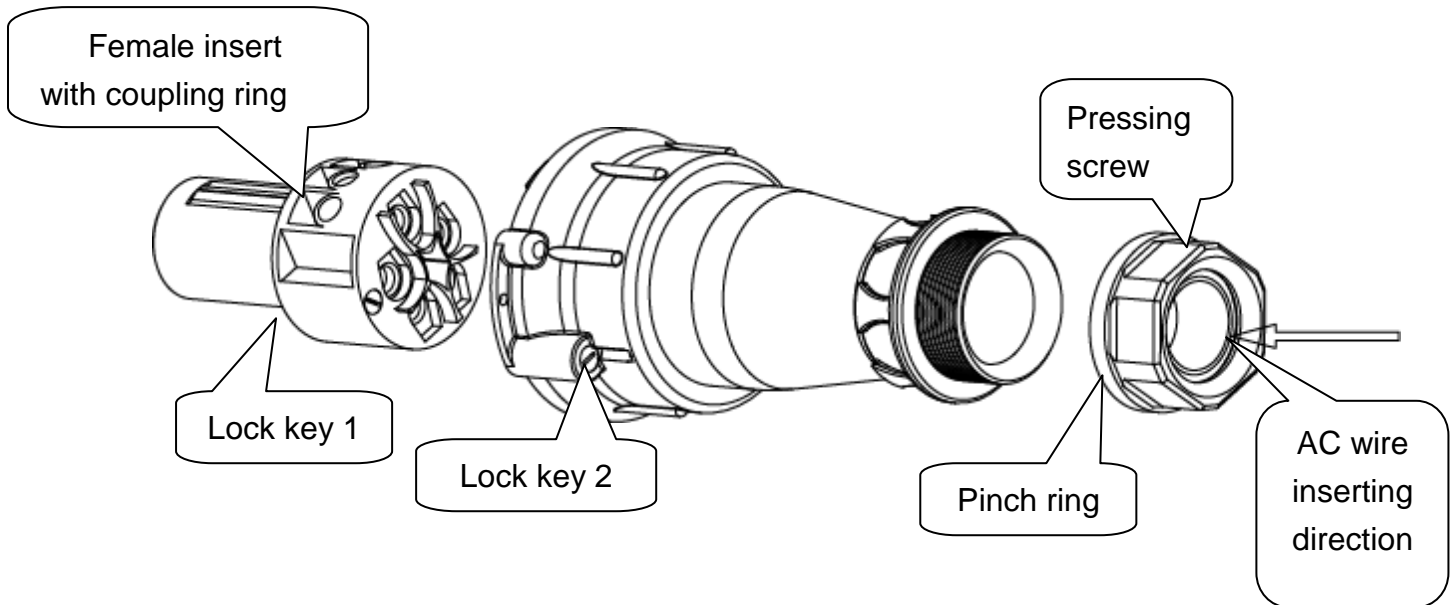

- Strip the wire sheath and conductor insulators the minimum amount necessary to insert the wires into the connection pins.
- Insert Line wire to **1**, Neutral wire to **N** and Ground wire to pin \oplus .
- Fully tighten the wire clamp screws in each connection pin.
- Assemble the socket again. Insert the whole socket into the inverter.
- Twist the coupling ring to receptacle on inverter. Make sure it is perfectly matched and tightly fastened.

Do not connect the AC power at this time

Step 3: Connect to the PV array (DC)

1. Make sure the maximum open circuit voltage (V_{oc}) of each PV string is less than 550V UNDER ANY CONDITION for SPH15, SPH20 & SPH40 and 600V for SPH50 & SPH60.
2. Ensure that the DC supply wires to the inverter are disconnected from the PV strings. We recommend that a disconnect switch or optional Solar Concentrator with disconnect is fitted between the PV array and the inverter. When making connections to the PV array outputs, the PV panels must be completely covered with shade material and the outputs must be shorted together and to earth ground. Always follow local and national codes and regulations for installation work on PV panels.
3. Verify with a DC voltmeter that there is no voltage between the positive and

negative DC wires and between each DC wire and earth ground.

4. Attach MC (Multi-contact® or Tyco) solar type connectors to the PV array DC positive and negative wires. Use red connectors for the positive DC wires and black connectors for the negative DC wires
5. Connect PV array DC positive wire(s) to the positive (+) terminal(s) of the inverter. Connect the PV array DC negative wire(s) to the negative (-) terminal(s) of the inverter. Each DC terminal on the SPH inverter is rated for a maximum of 20A DC current. Ensure that the maximum short circuit current of each PV string does not exceed 20A DC.

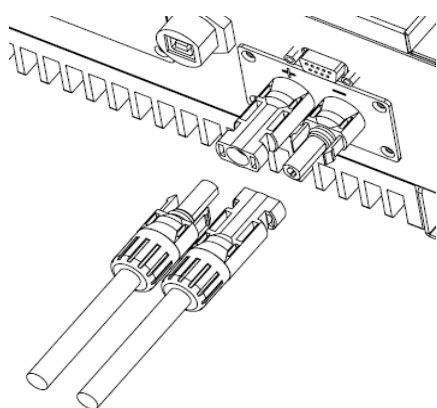

SPH15, SPH20 & SPH30 - 1 pair

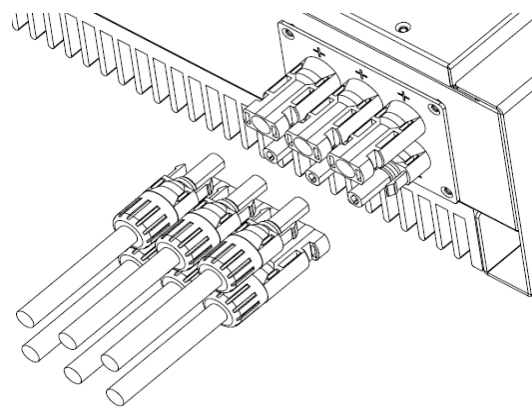

SPH40, SPH50 & SPH60 - 3pairs

When connecting the DC terminals, ensure that the polarity is correct. Incorrect connection may permanently damage the unit!

Step 4: Test the installation

1. Remove any protective short circuits applied to the PV array output.
2. Remove any shade material from the PV panels and ensure that the PV array is illuminated by sunshine.
3. Turn on the external DC switch (if fitted).
4. After connecting the DC¹, the message sequence on the LCD display should be "INV Waiting" → "No Utility" and the RED fault LED keeps on.
5. Fit any fuses removed from the AC supply. Close the AC breaker or switch and apply AC power to the inverter.
6. Verify that the inverter starts to work after a short delay. (This may take a few minutes to verify that the electric grid is stable.)
7. If inverter works normally, the LCD display panel will show "Working mode" and power is delivered to the electric grid. If there are any problems refer to the Troubleshooting section for possible resolutions.
8. The installation test is complete.

¹ Do not connect the AC power at this stage

4. Inverter status

The SPH Inverter is designed to be user friendly. The status of the inverter can be easily understood from the display panel.

Display information

- **LED lamps**

There are 2 operating status LED lamps on the unit.

Power LED (Blue): Lit when the unit is working and transferring power.

Dark when the unit is shutdown or in fault mode.

Status LED (Red): Lit when the unit is in fault or failure mode.
(See the display panel for more details.)

Dark in normal or shutdown operation.

- **LCD display panel**

- Normal operation

The display panel will show "Working Mode" during normal operation.

In "Working Mode", press the display button to enter "Meter Mode". In "Meter Mode" the display panel shows operating information. Each time the display button is pressed, the value changes to the next item:

O/P WATT =

PV VOLT =

PV CUR =

GRID VOLT =

GRID FREQ =

O/P CUR =

xxx KWH (O/P energy)

RATING= xx KW (PV Inverter Rating)

M CPU Ver. xxx (Firmware version of Master CPU)

S CPU Ver. xxx (Firmware version of Slave CPU)

- 1) If the display panel button is untouched for over 5 seconds, the display panel will return to "Working Mode".

- 2) If the display panel button is pressed and held for over 5 seconds, the display will "Freeze" (Lock) at the selected display screen.
- 3) The display screen "Freeze" (Lock) is released when the display button is pressed again and held for over 5 seconds.

In "Working Mode", press the display button and hold for over 5 seconds to enter "Settings Mode". The display panel will then show "Setting". Each time the display button is pressed, the setting changes to the next item:

Contrast setting > Press button for over 5 seconds to enter
Press button to select: Contrast 1 to Contrast 5
Then press button for over 5 seconds
LCD will show "Setting", Contrast setting is OK.

Language setting > Press button over 5 seconds to enter
Press button to select: English or German.
Then press button for over 5 seconds
LCD will show "Setting", Language setting is OK.

- 4) If the display panel button is untouched for over 5 seconds, the display panel will return to "Working Mode".

LCD Display Panel Setting

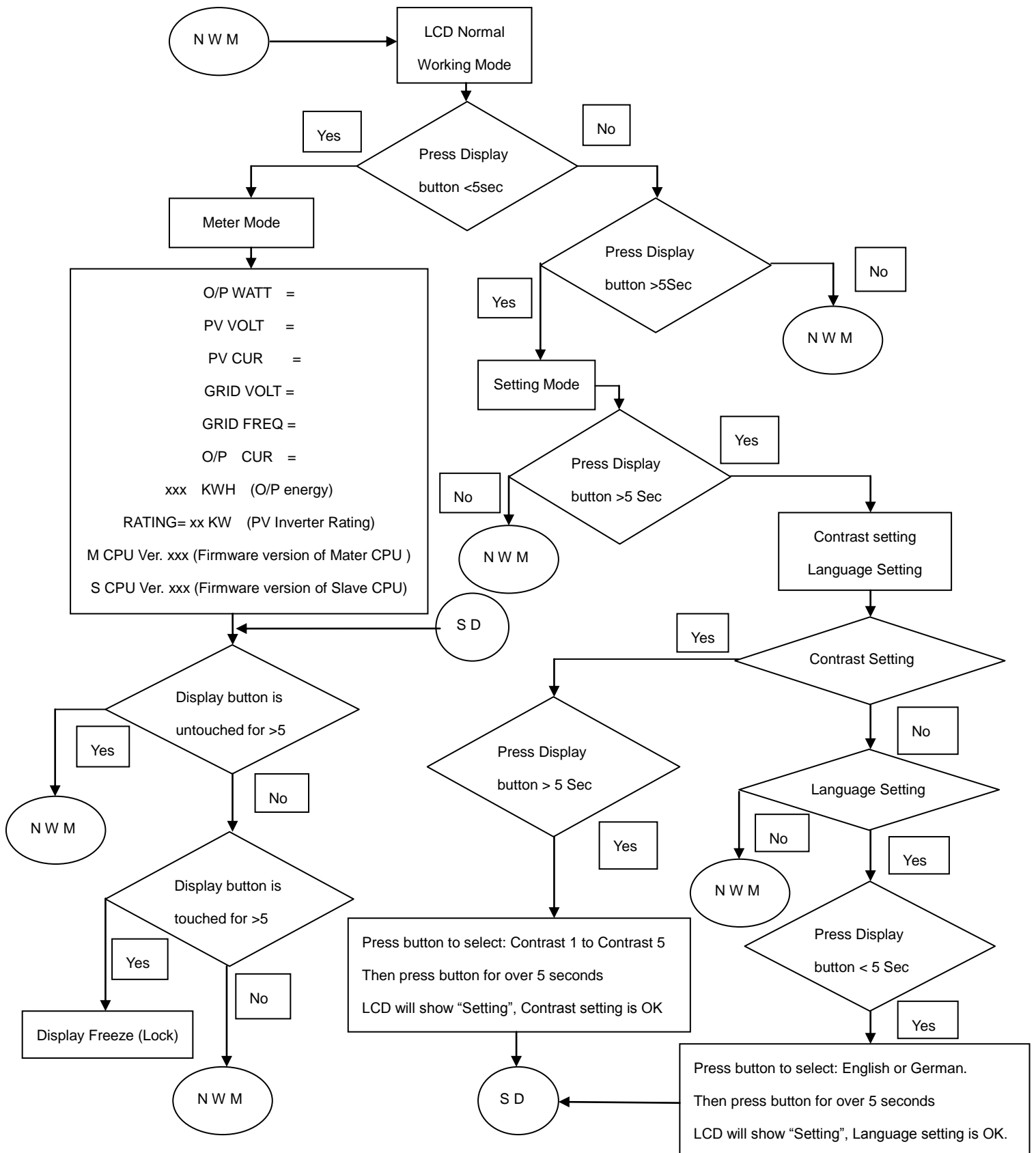

- Fault condition

The display panel will show the Error Message during fault conditions. The table shows the full list of messages with an explanation of the fault. See the Troubleshooting section for further information on fault resolution.

Error Message	Explanation
No Utility	Grid voltage is not detected
PV Over Voltage	PV voltage is too high
DC Bus High	Internal DC bus voltage is too high
DC Bus Low	Internal DC bus voltage is too low
Over Temperature	Internal temperature is too high
Grid Fault	Grid voltage or frequency is out of range
Device Fault	Internal fault with inverter circuits
Isolation Fault	PV panel ground isolation problem
Impedance Fault	Grid impedance fault (or grid disconnected)
Ground I Fault	Grid output ground leakage current too high
Relay Failure	Grid output relay failure
DC INJ High	Grid DC injection too high
Ref 2.5V Fault	2.5V reference voltage internal circuit fault
DC Sensor Fault	Grid DC current sensor internal fault
GFCI Fault	Ground Fault Current Interrupt fault
Sci Fault	Internal Master/Slave communication fault
Consistent Fault	Internal Master/Slave value mismatch fault
CPU Ver Mismatch	Internal Master/Slave firmware incompatible
EEPROM Fault	Internal non-volatile memory fault
Grid V Mismatch	Internal Master/Slave grid voltage mismatch
Grid F Mismatch	Internal Master/Slave grid frequency mismatch
Grid Z Mismatch	Internal Master/Slave grid impedance mismatch
GFCI Mismatch	Internal Master/Slave ground fault value mismatch
DC Curr Mismatch	Internal Master/Slave grid DC current mismatch

- **Typical display panel messages**

The table explains typical display panel messages that occur depending on the SPH inverter operating status and display panel mode.

Operating conditions	Display message	Description
Normal working status		
Power off	No display	PV inverter is totally shutdown, PV voltage $\leq 90V$.
Standby	INV Standby	$90V < \text{Input voltage} < = 100V$.
Initialization & waiting	INV Waiting	PV input voltage range 100V to 150V during start-up. Inverter is waiting for feeding to grid.
Check grid	Testing	When PV voltage $> 150V$, inverter is checking grid conditions.
Normal operation, MPPT	Working Mode	Inverter is supplying power to grid.
Monitoring parameters		
Grid output power	O/P Watt=xxxxW	The grid output power in Watts.
Accumulated energy information	xxxxx KWh	Total energy which has been supplied to the grid since the inverter was installed.
Grid voltage	GRID VOLT=xxx.xV	Grid (rms) voltage in Volts.
Grid frequency	GRID FREQ=xx.xHz	Grid frequency in Hertz.
Grid output current	O/P CUR=xx.xA	Grid (rms) current in Amps.
PV panel voltage	PV VOLT=xxx.xV	PV panel DC voltage in Volts.
System fault		
Isolation failure	Isolation Fault	Earth fault of the PV-panels or failure of surge voltage protection.
GFCI (Ground Fault Current Interrupter) active	Ground I Fault	Current on the ground conductor is too high.
Grid failure	Grid Fault	Grid measured data is beyond the specification (voltage & frequency).
Abnormal Grid Impedance	Impedance Fault	1.Grid impedance higher than limit. 2.Grid impedance change is faster than limit.
No grid utility voltage	No Utility	1.Inverter is not connected to grid 2.Grid voltage is not present.
DC-Input voltage too high	PV Over Voltage	DC-Input voltage is higher than the maximum limit (500VDC).
Inverter failure		
Master/Slave CPU Consistency failure	Consistent Fault or Mismatch	The readings of 2 microprocessors are not consistent. It is probably caused by CPU and/or other circuit malfunction.
Bus failure	DC Bus High DC Bus Low	DC-Bus voltage too high or too low.
Device failure	Device Fault	The device is unable to return to normal status.
Temperature too high	Over	The internal temperature is higher

Operating conditions	Display message	Description
	Temperature	than the permitted operating range.
Firmware Update		
Updating Master CPU firmware	Master Flash	The internal program is updating Master CPU through RS232 interface.
Updating Slave CPU firmware	Slave Flash	The internal program is updating Slave CPU through RS232 interface.

5. Communication interfaces

The SPH inverter is equipped with an RS232 and USB communication interface as standard. A communication slot is also provided for advanced communications options.

The status of the inverter can be monitored via the communications interfaces using a PC with the monitoring software "Solar control". The software is free. The software will be downloaded from www.clenergy.com.au/download.php. Download the "SPH - Monitoring Software V1.26" and install in your computer.

Installation and service technicians can also change the unit setting and download new firmware via the RS232 interface using "PV_Reflash" software.

1. RS232: The SPH inverter is equipped with a 3-wire RS232 interface using a DB9 socket. This is located under the RS232 cover on the bottom of the unit. The table below defines the connector pin functions. N.C. means "No Connection".

Pin	Assignment Description
1	N.C.
2	TxD
3	RxD
4	N.C.
5	Common
6	N.C.
7	N.C.
8	N.C.
9	N.C.

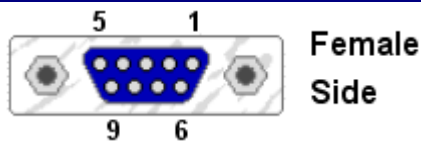

2. Optional communication slot: This slot is a very powerful expansion slot. The SPH unit can accept a special communication function card in this slot. There are 2 kinds of cards available now. One is an RS485 card and the other is a SNMP (Simple Network Management Protocol) card. In the future, other cards may be developed. For detailed information, please refer to the instruction manual of the individual card.

6. Troubleshooting

When installed and operated correctly, the SPH inverter will give many years of trouble free operation. Sometimes fault messages will be displayed due to abnormal conditions on the PV array or electric grid. These messages will clear automatically and the unit will restart once the PV array voltage and electric grid conditions return to the normal ranges. Occasionally you may experience a fault message that does not clear automatically when the conditions return to normal. This may be due to a problem with the overall PV installation, or an internal fault of the SPH inverter.

If the inverter continues to show a fault message then you may perform the visual inspection and procedure ONLY.

If you are a qualified solar inverter Maintenance technician you may be able to perform other tests as below.

Do not remove the covers. Warning - Risk of Electric Shock. Please follow the below instructions

Visual Inspection

- 1 Check the status of the Inverter to AC utility connection switch or MCB Off/On
- 2 Check the status of the Inverter to Solar panel connection switch or MCB Off/On
- 3 Check the status of the RED LED on the Inverter Off/On
- 4 Check the status of the BLUE LED on the Inverter Off/On
- 5 Check the error message on the LCD display on the Inverter
- 6 Check the smartmeter been installed

Failure Verification

- 1 Turn on the external DC switch
- 2 After connecting the DC , Check the message sequence on the LCD display should be “INV Waiting” → “No Utility” and the RED fault LED keeps on.
- 3 Turn on AC switch or MCB to power on the inverter.
- 4 Verify that the inverter starts to work after a short delay. (This may take a few minutes to verify that the electric grid is stable.)
- 5 If inverter works normally, the LCD display panel will show “Working mode” and power is delivered to the electric grid. Otherwise the LCD display an error.

6 The failure verification test is complete.

Some common fault messages and resolutions are explained below. If the resolution procedure does not resolve the problem, contact your equipment installer or supplier for assistance. Actions shown in **bold letters should only be performed by a qualified electrician or electrical technician.**

Fault	Display	Possible actions
	No Utility	<ol style="list-style-type: none"> 1.No grid voltage. Check the grid voltage by multi-meter. 2.Check grid connection, such as wire and connector to the inverter. 3.Check breaker between inverter and grid; if it is tripped, DO NOT CLOSE again, get an electrician to check the wiring and inverter.
	Grid Fault	<ol style="list-style-type: none"> 1.Wait for grid power to return to normal. If the grid returns to normal, the inverter will start again automatically within 5 minutes. 2.Check the grid voltage and frequency by multi-meter. Make sure grid voltage and frequency meet the specifications. 3.Contact your inverter service representative to discuss adjusting the operating range, if permitted by the electricity provider.
System fault	Impedance Fault	<ol style="list-style-type: none"> 1.The grid impedance is higher than the permissible value. 2.Wait for grid power to return to normal. If the grid returns to normal, inverter will start again automatically within 5 minutes. 3. Check the wires between inverter and grid. For high impedance Connections get an electrician to increase the wire size. 4. Contact your inverter service representative to discuss adjusting The operating range, if permitted by the electricity provider.
	Isolation Fault	<ol style="list-style-type: none"> 1.Check the impedance between PV (+) & PV (-) and earth ground. The impedance must be larger than 8MΩ. If the impedance is low a ground fault may exist in the PV array or wiring. Contact your PV array service provider or electrician. 2.If above actions do not fix the problem, the isolation detection circuit may be faulty. Contact your inverter service representative.
	Ground I Fault	<ol style="list-style-type: none"> 1.This is caused by too high ground current. 2.Disconnect the inverter from the grid power. Check the AC wiring and connection system. 3.After the cause is cleared, reconnect the grid power. Check the status of the inverter. 4.If above actions do not fix the problem, the GFCI circuit may be faulty. Contact your inverter service representative.

Fault	Display	Possible actions
Inverter failure	Over Temperature	<ol style="list-style-type: none"> 1.The internal temperature is higher than specified normal value. 2.Reduce the ambient temperature by shading or ventilation improvements or move inverter to cooler place. 3.If this is not effective, a temperature sensor may be faulty. Contact your inverter service representative.
	PV Over Voltage	<ol style="list-style-type: none"> 1. Check the PV open-circuit voltage. This should be less than 500VDC. 2. If the PV voltage is much less than 500VDC (e.g. <430V), measure the DCV by multi-meter, compare the readings on meter and LCD. If the readings differ by >5%, contact your inverter service representative.
	Device Fault	<ol style="list-style-type: none"> 1.This is caused by an inverter malfunction. 2.Disconnect PV (+) or PV (-) from the input, start the unit again. 3.If it does not work, contact your inverter service representative.
	Consistent or Mismatch Fault	<ol style="list-style-type: none"> 1.This is caused by inconsistent values between the main (master) and redundant (slave) controllers of the inverter. 2.Disconnect PV (+) or PV (-) from the input, start the unit again. 3.If this does not work, contact your inverter service representative.

7. Specification

Model	SPH15	SPH20	SPH30	SPH40	SPH50	SPH60
Nominal Output Power	1500W	2000W	3000W	4000W	5000W	6000W
Maximum Output Power	1650W	2200W	3300W	4400W	5000W	6000W
PV Input						
Nominal DC voltage	360 VDC					
MPPT range	150 to 500VDC			150 to 600VDC		
Working Range	100 to 500VDC			100 to 600VDC		
Max PV Open circuit voltage (Voc)	550V DC			600VDC		
Max. input current at 360V DC	7.5A DC	10A DC	15A DC	20A DC	25A DC	30A DC
Max. input current limited to	8.77A DC	11.57A DC	17.36A DC	20A DC	25A DC	30A DC
Max. input power	1755W	2315W	3470W	4580W	5205W	6250W
Grid Output						
Operational voltage	190VAC to 270VAC					
Operational frequency	47 - 53 Hz / 57 -63 Hz, auto selection					
Current distortion	< 3%					
Power factor	> 0.99					
The Maximum Grid Impedance Applicable	NA	NA	NA	NA	0.283 Ω (= 0.24Ω+j0.15Ω)	0.283Ω (= 0.24Ω+j0.15Ω)
Conversion efficiency (max)	>94%	>95%	>95%	>96%	>96%	>96%
European efficiency	>93%	>94%	>94%	>95%	>95%	>95%
Environment						
Protection degree	IP65					
Operation temperature	-25 to 55°C					
Humidity	0 to 95%, non-condensing					
Heat Dissipation	Convection					
Acoustic noise level	<40dB,A-weighted.					
Communication & features						
Comm. Interface	RS232 standard, USB, SNMP & RS485 optional					
F/W upgrade	Yes, via RS232					
Technology						
Transformerless	Yes					
Waveform	Sine PWM					
Mechanical						
W´D´H (mm)	362x312x131	362x312x131	362x312x141	384x464x131	515x464x142	515x464x142
Weight (kg)	14	14	14	21	27	27

*The product's specifications are subject to change without notice.

Clenergy China

N305 WeiYe Building, Pioneer Park

Xiamen, China, 361006

Tel: +86-592 -5781288

Fax :+86- 592- 5782298

www.clenergy.com.cn

Clenergy Europe

(including Italy , France and Germany)

An der Welle 4

60322 Frankfurt

Tel: +49 69 7593 - 8499

Fax: +49 69 7593 - 8200

www.clenergy-de.de

Clenergy Australia

(including the US and Pacific)

18/20 Duerdin St,

Clayton VIC 3168

Tel: +61 3 9017 6688

Fax: +61 3 9017 6668

www.clenergy.com.au